

6	7	8	9
REV.	ZONE	DESCRIPTION	DESIGN
A		初版发行	Jack
			DATE
			21.08.06

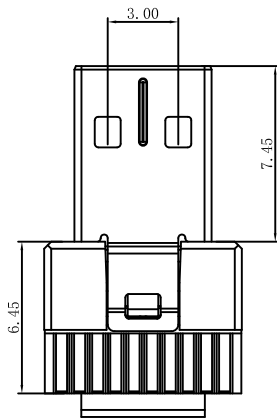
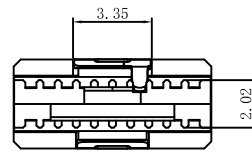
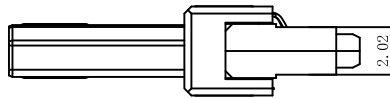
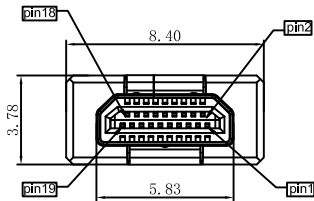
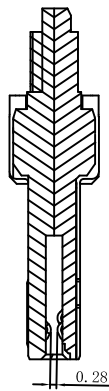
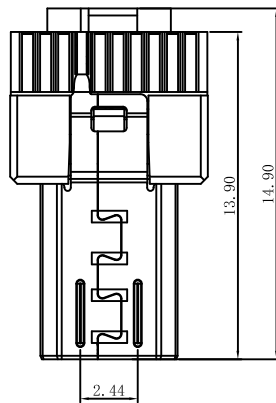

技术要求:

1. 材质: 端子: C5191-H T=0.15mm  
胶芯: LCP,  
外壳: SUS-H T=0.15mm
2. 电镀: a. 镀层: 外壳镀铜; 镍底 100U, 全金1U,3U,5U  
b. 镀金: 端子1U" 3U" 5U" 15U" 30U"

电气性能:

1. 额定电压: 30V
2. 额定电流: 0.8A
3. 接触阻抗: 10毫欧
4. 高压: 未插入 250V 插入 150V
5. 绝缘阻抗: 未插入 100兆欧 插入 10兆欧

机械性能:

1. 插入力: 44N max
2. 拔出力: 5N min
3. 插拔寿命: 5000 cycles

PIN NO	SINGAL NO	PIN NO	SINGAL NO
PIN 1	Hot Plug Detect	PIN 2	Utility
PIN 3	TMDS Data2+	PIN 4	TMDS Data2 Shield
PIN 5	TMDS Data2-	PIN 6	TMDS Data1+
PIN 7	TMDS Data1 Shield	PIN 8	TMDS Data1-
PIN 9	TMDS Data0+	PIN 10	TMDS Data0 Shield
PIN 11	TMDS Data0-	PIN 12	TMDS Clock+
PIN 13	TMDS Clock Shield	PIN 14	TMDS Clock-
PIN 15	CEC	PIN 16	DDC/CEC Ground
PIN 17	SCL	PIN 18	SDA
PIN 19	+5V Power		

Unless otherwise specified tolerances are	
X.X	±0.20
X.XX	±0.15
X.XXX	±0.10
X°	±2.0°
X.X°	±1.0°

# Coorle Technology

DRAW NO.	DATE	DRAW NAME:
DWN	21.08.06	HDMI D TYPE 20P公头 焊线式
CHK		P/N :
APVD		

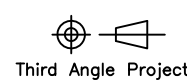

FINISH	UNIT	SCALE	WEIGHT	REV	SHEET
MATERIAL	mm	1:1		A	1 OF 1

FILE:

日期	修改人	代号	修改方式	修改原因

NOTE:

- 1: MATERIAL: PBT+30% GF.
- 2: COLOR: BK
- 3: 表面不可以有拉伤. 缩水. 气纹等
- 4: 装配位置毛边不得超过0.05MM

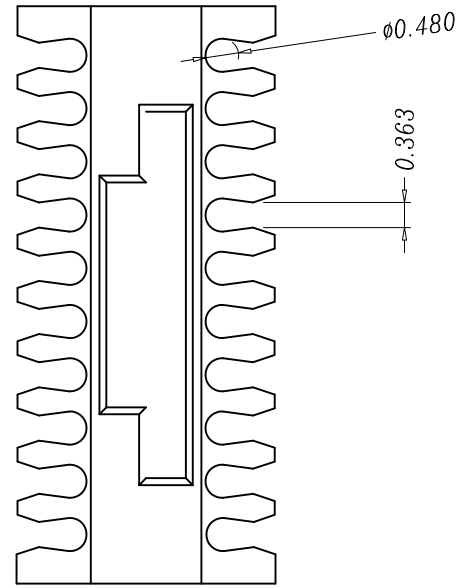
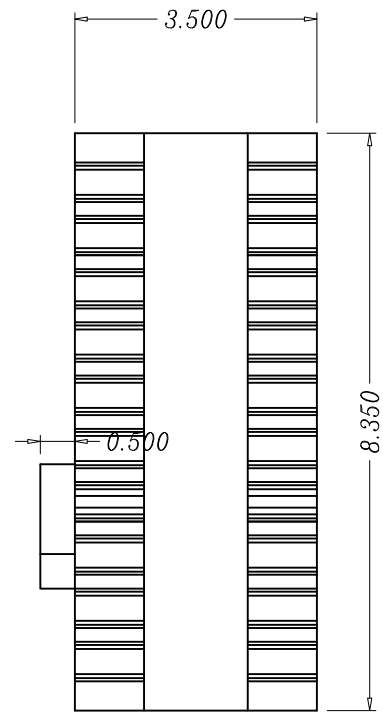
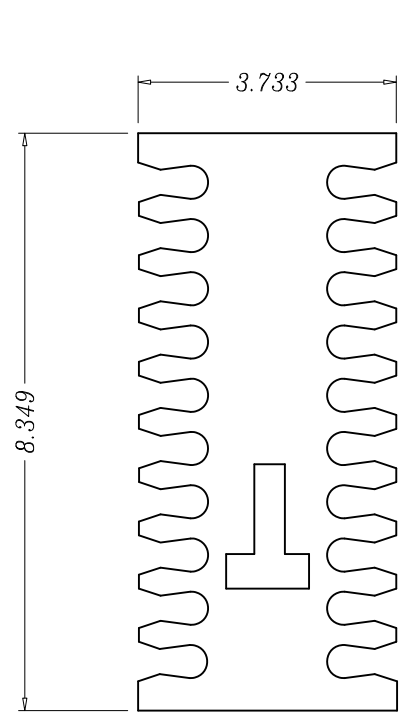
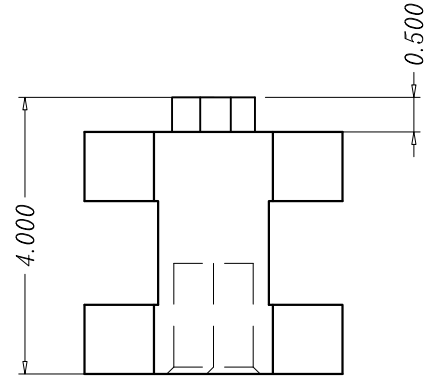

- 铣下料
- 铣作孔
- 热处理
- 电火花 (细孔)
- 线切割 (快, 慢)
- 磨六面
- 磨下料
- 磨达图
- 电脑锣
- 刻字
- 蚀纹
- 电镀
- 抛光

公差	$X \pm 0.2$	$X \pm 0.10$	$.XX \pm 0.05$	$.XXX \pm 0.02$	$.XX^\circ \pm 1^\circ$	单位	MM
材质	PA9T	热处理		数量		投影法	
模穴		收缩率		比例		出图日期	
设计	TSM	业务电话		核准		试模日期	

Coorle Technology

零件名:	产品图	模具号:	D1	图号	001
产品名:	D型20P 32号线夹			版本	A0

REV.	ZONE	DESCRIPTION	DESIGN	DATE
A		初版发行	Jack	21.08.16

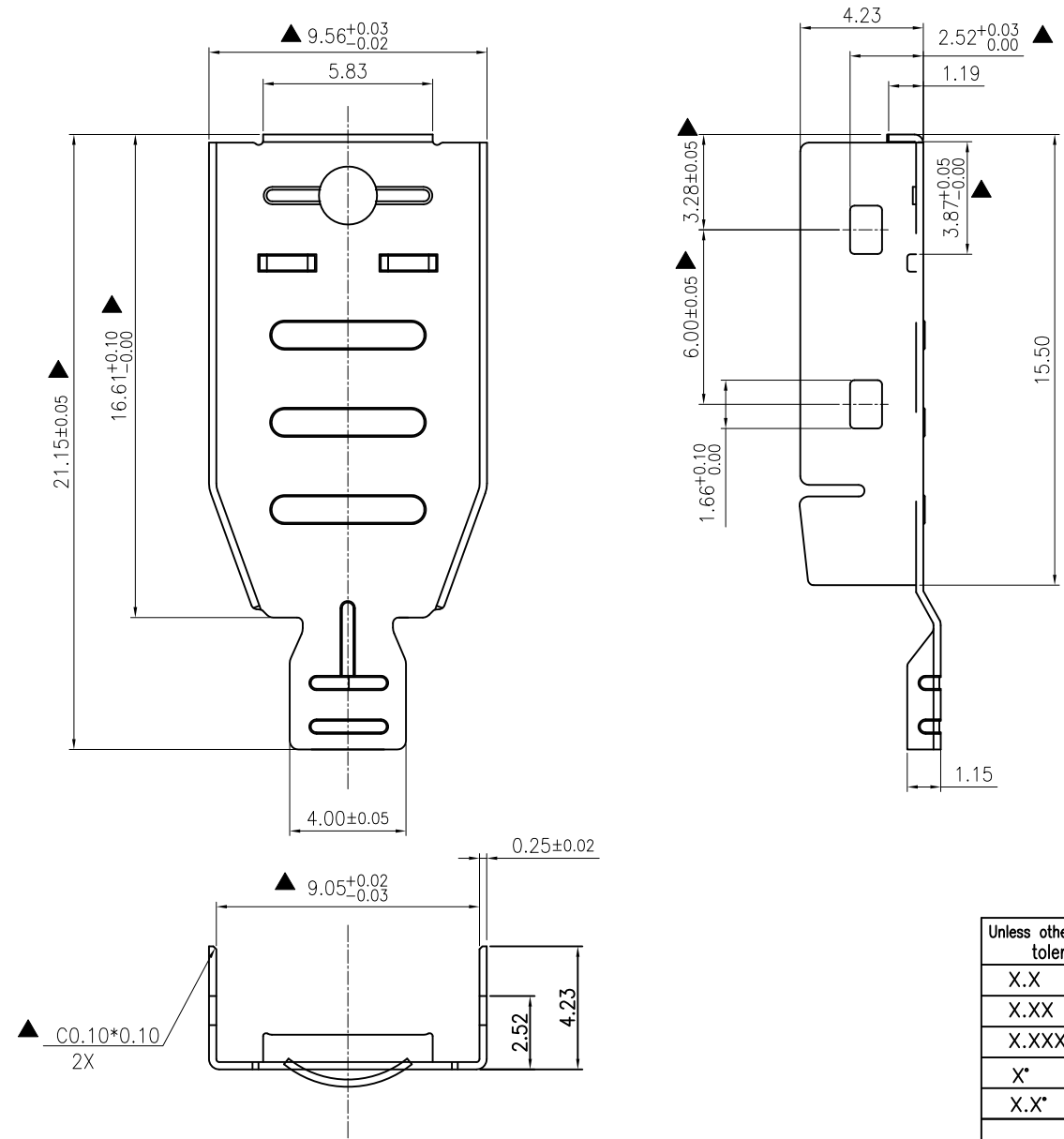

- 注释:
1. 材质: SPCC; T= 0.25±0.02mm;
  2. 电镀要求:  
打铜底100-120", 再镀镍80~120U"; 盐雾24H
  3. 标识 "▲" 为重点管控尺寸;
  5. 产品不能有油脂, 润滑剂, 压伤和其它的外观不良;
  6. 所有的折弯为90°, 除了特殊标注;

Unless otherwise specified tolerances are		Coorle Technology						
X.X	±0.20	DRAW NO.	DATE	DRAW NAME:				
X.XX	±0.15			HDMI D TYPE 马口铁 上盖 OD:6.5mm				
X.XXX	±0.10	DWN	21.08.16	P/N :				
X*	±2.0°	CHK						
X.X*	±1.0°	APVD						
 Third Angle Project		FINISH		UNIT	SCALE	WEIGHT	REV	SHEET
		MATERIAL		mm	1:1		A	1 OF 1

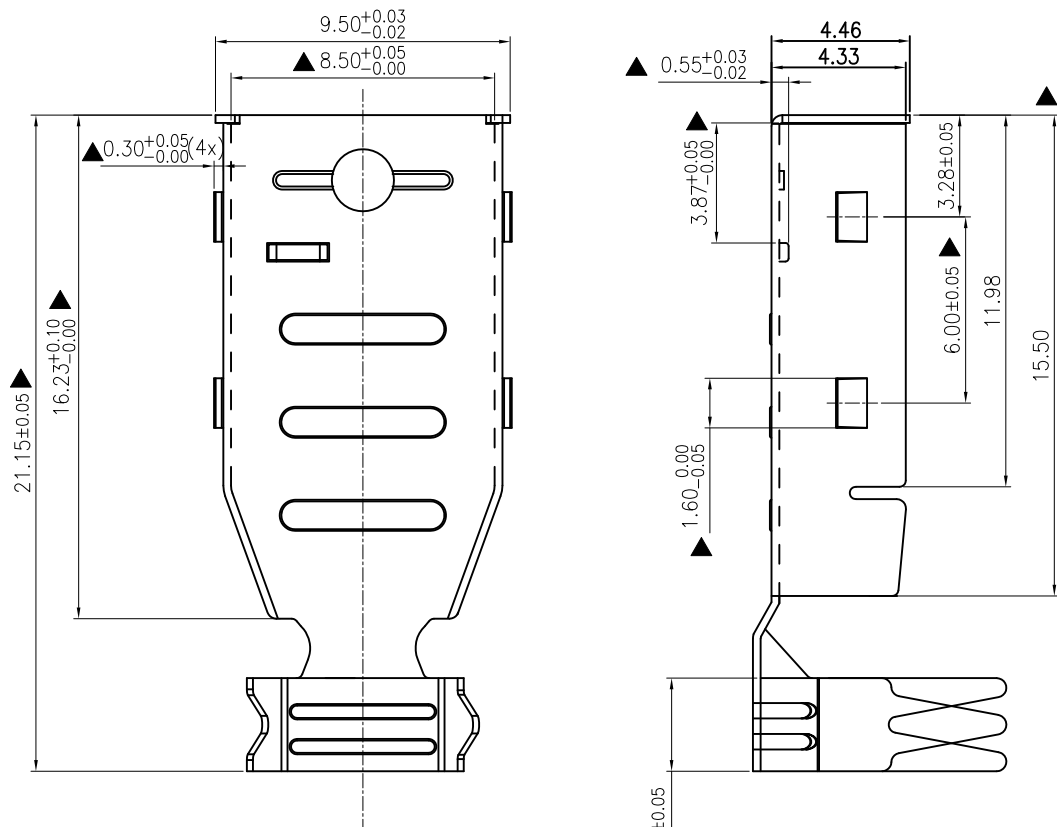

REV.	ZONE	DESCRIPTION	DESIGN	DATE
A		初版发行	Jack	21.08.16

注释:

1. 材质: SPCC; T= 0.25±0.02mm;
2. 电镀要求: 打铜底100~120U", 再镀镍80~120U"; 盐雾24H
3. 标识 "▲" 为重点管控尺寸;
5. 产品不能有油脂, 润滑剂, 压伤和其它的外观不良;
6. 所有的折弯为90°, 除了特殊标注;

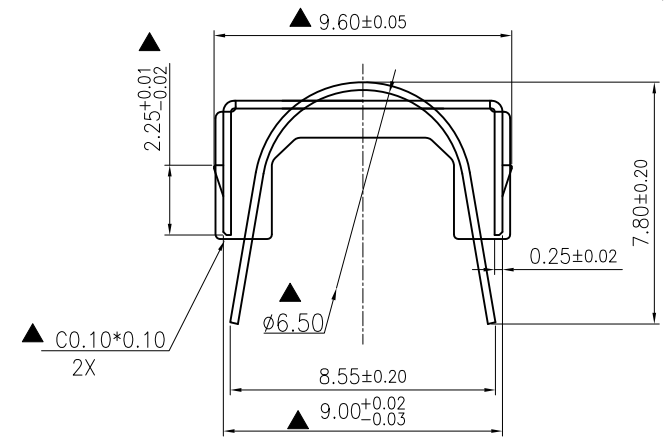

Unless otherwise specified tolerances are		Coorle Technology						
X.X	±0.20	DRAW NO.	DATE	DRAW NAME: HDMI D TYPE 马口铁 下盖 OD:6.5mm				
X.XX	±0.15							
X.XXX	±0.10	DWN	21.08.16	P/N :				
X*	±2.0°	CHK						
X.X*	±1.0°	APVD						
 Third Angle Project		FINISH		UNIT	SCALE	WEIGHT	REV	SHEET
		MATERIAL		mm	1:1		A	1 OF 1